

RXC

ROOM CO₂
SENSOR / SWITCH

Mounting and operating instructions



Table of contents

SAFETY AND PRECAUTIONS	3
PRODUCT DESCRIPTION	4
ARTICLE CODES	4
INTENDED AREA OF USE	4
TECHNICAL DATA	4
STANDARDS	4
OPERATIONAL DIAGRAMS	5
WIRING AND CONNECTIONS	5
MOUNTING & OPERATING INSTRUCTIONS IN STEPS	5
MODBUS REGISTER MAPS	8
VERIFICATION OF INSTALLATION INSTRUCTIONS	9
TRANSPORT AND STOCK KEEPING INFORMATION	9
WARRANTY INFORMATION AND RESTRICTIONS	9
MAINTENANCE	9

SAFETY AND PRECAUTIONS



Read all information, the datasheet, mounting instructions and wiring scheme before working with the product. For personal and equipment safety, and for optimum product performance, make sure you entirely understand the contents before installing, using, or maintaining this product.



For safety and licensing (CE) reasons, unauthorised conversion and / or modifications to the product are not permitted.



The product must not be exposed to abnormal conditions, such as: extreme temperatures, direct sunlight or vibrations. Chemical vapours with high concentration in combination with long exposure times can affect the product performance. Make sure the work environment is as dry as possible, check for condensation spots.



All installations shall comply with the local health and safety regulations and local electrical codes. This product can only be installed by an engineer or a technician who has an expert knowledge of the product and safety precautions.



Avoid contacts with energised electrical parts, always treat the product as if it is life. Always disconnect the power source before connecting the power cables, servicing or repairing the product.



Always verify that you apply appropriate power supply to the product and use wires with appropriate size and characteristics. Make sure that all the screws and nuts are well tightened and fuses (if any) are fitted well.



Recycling of equipment and packaging should be taken into consideration and disposed in accordance with local and national legislation / regulations.



In case there are any questions that are not answered, please contact your technical support or consult a professional.

PRODUCT DESCRIPTION

The RXC is a room sensor / switch which measures the concentration of CO₂ in the air. It provides four pre-defined ranges and one user-definable range. The unit is equipped with Modbus RTU (RS485) communication and has an analogue output and a relay output.

ARTICLE CODES

Code	Supply	Connection
RXC-G	15–24 VAC ± 10 % 18–34 VDC	3 - wire
RXC-F	18–34 VDC	4 - wire

INTENDED AREA OF USE

- Monitoring and maintaining CO₂ level in buildings and private houses
- For indoor use only

TECHNICAL DATA

- Analogue output: 0–10 VDC / 0–20 mA
- Relay output: C/O (230 VAC / 2 A)
- Power consumption:
 - ▶ no load: max. 50 mA
 - ▶ full load: max. 70 mA
- Load resistance:
 - ▶ 0–10 VDC mode > 500 Ω
 - ▶ 0–20 mA mode < 500 Ω
- Selectable sensor ranges: 450–1.850 ppm / 0–1.000 ppm / 0–1.500 ppm / 0–2.000 ppm
- Free selectable sensor range via Modbus: 0–2.000 ppm
- Switching point: selectable by trimmer or via Modbus
- Selectable hysteresis: 50 / 100 / 150 / 200 ppm
- Enclosure:
 - ▶ rear lid: plastic ABS, black (RAL9004)
 - ▶ front cover: ASA, ivory (RAL9010)
- Protection standard: IP30 (according to EN 60529)
- Operating ambient conditions:
 - ▶ temperature: 0–50 °C
 - ▶ rel. humidity: < 95 % rH (non-condensing)
- Storage temperature: -40–50 °C

STANDARDS

- Low Voltage Directive 2006/95/EC 
- EMC Directive 2004/108/EC: EN 61326
- WEEE Directive 2012/19/EU
- RoHs Directive 2011/65/EU

OPERATIONAL DIAGRAMS

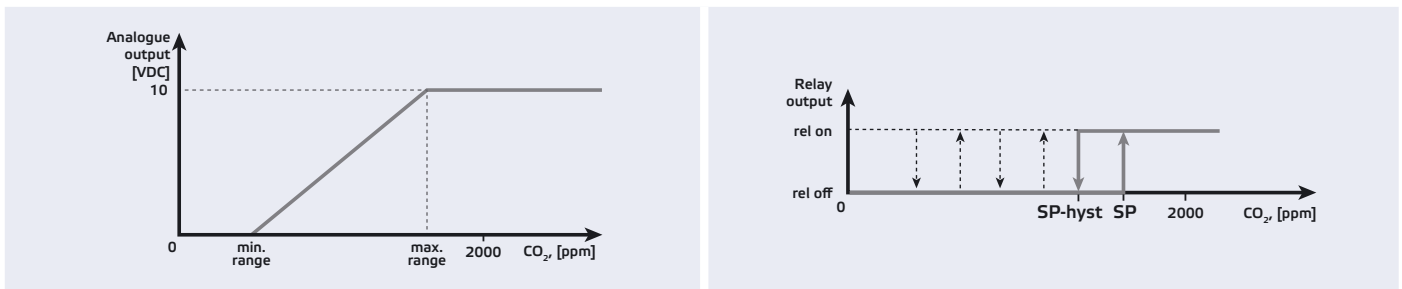

WIRING AND CONNECTIONS

Vin	Positive DC voltage / AC ~
GND	Ground / AC ~
A	Modbus RTU (RS485) signal A
/B	Modbus RTU (RS485) signal /B
Ao1	Analogue output (0–10 VDC / 0–20 mA)
GND	Ground
NO1	Normally open contact
COM1	Common contact
NC1	Normally closed contact
Connections	Cable cross section: max. 1,5 mm ²

MOUNTING & OPERATING INSTRUCTIONS IN STEPS

Before you start mounting the RXC room CO₂ sensor / switch, read carefully "Safety and Precautions". Choose a smooth surface for an installation location (a wall, panel and etc.).

1. Open the white cover by releasing the locking plates on both sides of the cover and remove it. (See **Fig. 1** *Locking plates release*.)
2. Insert the cables through the cable opening of the enclosure rear lid. (See **Fig. 2** *Mounting dimensions*.)

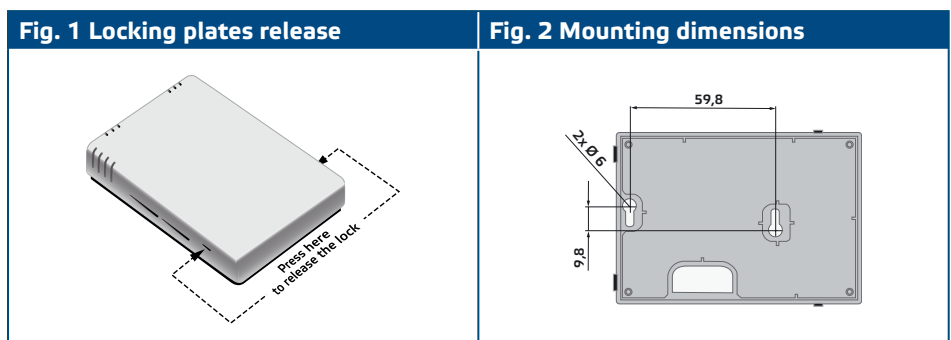

3. Do the wiring according to the wiring diagram (see **Fig. 3**) using the legend information from section **“Wiring and connections”**.

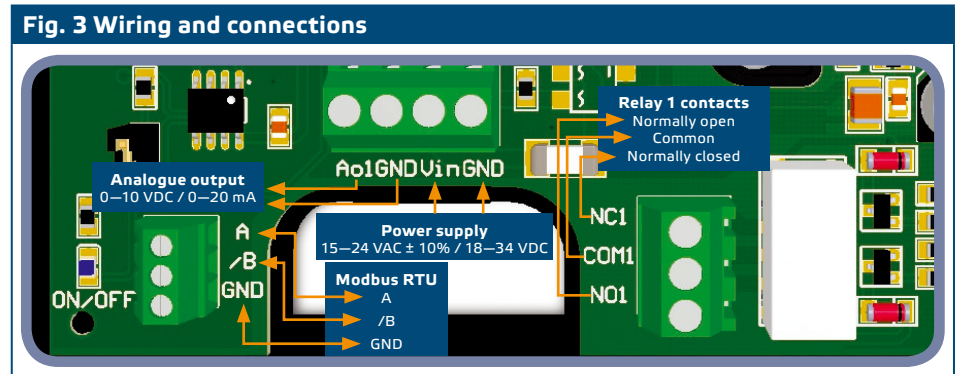

4. Check if your unit starts or terminates the network (see **Example 1** and **Example 2**). If it does not, remove the NBT jumper (see **Fig. 4**).

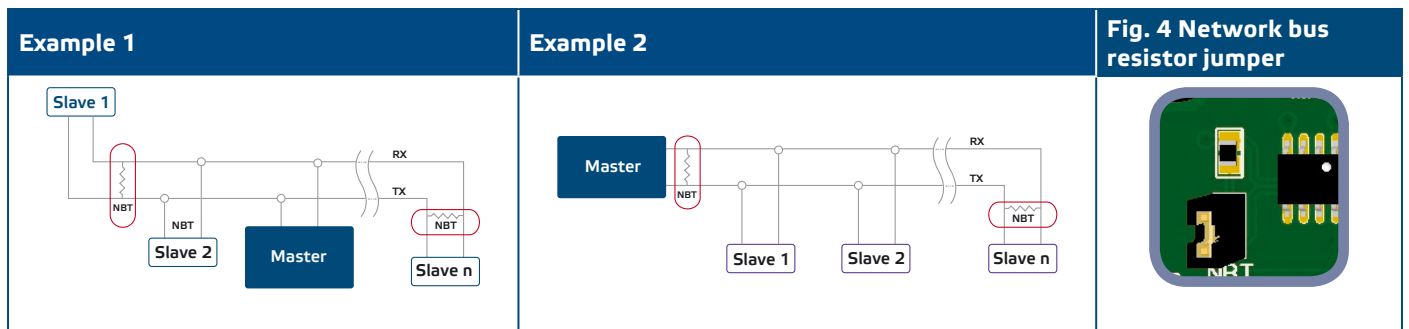

ATTENTION

If an AC power supply is used with any of the units in a Modbus network, the GND terminal should NOT BE CONNECTED to other units on the network or via the CNVT-USB-RS485 converter. This may cause permanent damage to the communication semiconductors and / or the computer!

5. Adjust the standalone settings:
 - 5.1 To select the analogue output mode, use jumper JP5. (See **Fig. 5 Analogue output selection jumper**.)
 - 5.2 To select the sensor range, use jumper JP3. (See **Fig. 6** and the enclosed information.)
 - 5.3 To select a hysteresis value, use jumpers JP8 and JP9. (See **Fig. 7** and the enclosed jumper combinations.)

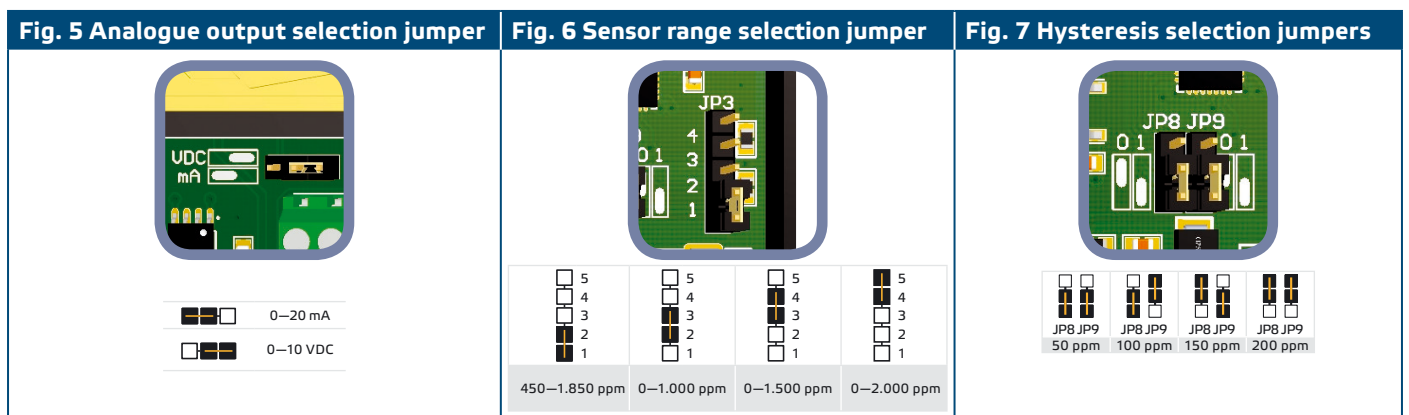

- 5.4 To reset the Modbus settings, put and hold jumper P1 for 20 seconds. (See **Fig. 8 Modbus reset jumper**.)
- 5.5 To select the setpoint, use trimmer VR1 (**Fig. 9**).

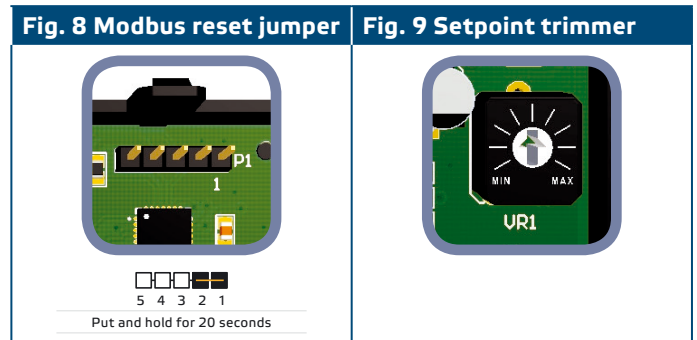

- 6. Close the enclosure and fix the cover.
- 7. Switch on the power supply

ATTENTION

Do not exceed the maximum power supply rating! Measure before installation! Unregulated 24 VAC supply units provide higher nominal output voltage and activate the integrated fuse protection.

ATTENTION

If a G-type article is using the same AC power supply source (transformer) as F-type article, a SHORT CIRCUIT may result when the power supply and analogue signal terminals are connected to the same common ground! In this case always connect different article types to separate AC transformers or use the same article version.

- 8. Customise the factory settings to the desired ones, through 3SModbus software (if necessary). For the default factory setting see **Table Modbus register maps**.

MODBUS REGISTER MAPS

INPUT REGISTERS					
		Data type	Description	Data	Values
1-3			Reserved, returns 0		
4	CO ₂ level	unsigned int.	Actual CO ₂ level	0–2.000	500 = 500 ppm
5-10			Reserved, returns 0		
11	Analog output value	signed int.	Value of the analog output	0–1.000	0 = 0 % 1.000 = 100 %
12	Relay status	signed int.	Relay status. When it is On, the contact between COM1 and NO1 is closed.	0–1	0 = Off 1 = On
13	CO ₂ range	signed int.	CO ₂ working range selected by jumper or holding register	1–5	1 = 450–1.850 ppm 2 = 0–1.000 ppm 3 = 0–1.500 ppm 4 = 0–2.000 ppm 5 = Custom
14	Setpoint	signed int.	Setpoint selected by trimmer or holding register	0–2.000	1.000 = 1.000 ppm
15	Hysteresis	signed int.	Hysteresis for the relay switching selected by jumpers or holding register	1–4	1 = 50 ppm 2 = 100 ppm 3 = 150 ppm 4 = 200 ppm
16	Setpoint out of range	signed int.	Flag that shows if the CO ₂ setpoint is out of the working range	0–1	0 = No 1 = Yes
17	Calibration timer	unsigned int.	Returns passed time (in percentages) for the 10-minute calibration procedure in progress. When inactive, it returns 0	0–100	100 = 100%
18-20			Reserved, returns 0		
20	CO ₂ sensor communication lost	unsigned int.	Flag that shows if the communication with the CO ₂ sensor module is lost	0–1	0 = No 1 = Yes

HOLDING REGISTERS						
		Data type	Description	Data	Default	Values
1	Device slave address	unsigned int.	Modbus device address	1–247	1	
2	Modbus baud rate	unsigned int.	Modbus communication baud rate	1–4	2	1 = 9.600 2 = 19.200 3 = 38.400 4 = 57.600
3	Modbus parity	unsigned int.	Parity check mode	0–2	1	0 = 8N1 1 = 8E1 2 = 8O1
4	Device type	unsigned int.	Device type. <i>Read only.</i>	RXC-X = 1003		
5	HW version	unsigned int.	Hardware version of the device (<i>Read only</i>)	XXXX		0 x 0310 = HW version 3.10
6	SW version	unsigned int.	Software version of the device (<i>Read only</i>)	XXXX		0 x 0190 = SW version 1.90
7	Operating mode	unsigned int.	Enables Modbus control and disables the jumpers and trimmers	0–1	0	0 = Standalone mode 1 = Modbus mode
8	Output overwrite	unsigned int.	Enables the direct control over the outputs. <i>Always settable. Active only if holding register 7 is set to 1.</i>	0–1	0	0 = Disabled 1 = Enabled
9-10			Reserved, returns 0			
11	CO ₂ range	signed int.	Selects the CO ₂ working range. <i>Always settable. Active only if holding register 7 is set to 1.</i>	1–5	1	1 = 450–1.850 ppm 2 = 0–1.000 ppm 3 = 0–1.500 ppm 4 = 0–2.000 ppm 5 = Custom
12	Minimum custom CO ₂ range	signed int.	Minimum value of the custom CO ₂ range. <i>Always settable. Active only if holding register 7 is set to 1 and register 11 is set to 5.</i>	0–Max	0	1.000 = 1.000 ppm
13	Maximum custom CO ₂ range	signed int.	Maximum value of the custom CO ₂ range. <i>Always settable. Active only if holding register 7 is set to 1 and register 11 is set to 5.</i>	Min–2.000	2.000	2.000 = 2.000 ppm
14	Setpoint	signed int.	Selected setpoint for the relay switching. <i>Always settable. Active only if holding register 7 is set to 1.</i>	0–2.000	1.000	1.000 = 1.000 ppm
15	Hysteresis	signed int.	Selected hysteresis for the relay switching. <i>Always settable. Active only if holding register 7 is set to 1.</i>	1–4	4	1 = 50 ppm 2 = 100 ppm 3 = 150 ppm 4 = 200 ppm
16	10-minute calibration	signed int.	Setting this register to 1 performs 10-minute calibration and it is automatically cleared after that. <i>The sensor measures the CO₂ level for 10 minutes and sets the lowest value at 400 ppm. Do not turn off the device during this procedure!</i>	0–1	0	1 = Starts calibration 0 = Idle
17	1-month calibration	signed int.	Setting this register to 1 performs 1-month calibration and it is automatically cleared after that. <i>The sensor measures the CO₂ level for 1 month and sets the lowest value at 400 ppm. Do not turn off the device during this procedure!</i>	0–1	0	1 = Starts calibration 0 = Idle
18-20			Reserved, returns 0			
21	Analog output overwrite value	signed int.	Overwrite value for the analog output. <i>Always settable. Active only if holding register 8 is set to 1.</i>	0–1.000	0	0 = 0 % 1.000 = 100 %
22-30			Reserved, returns 0			

To find out more about Modbus over serial line, follow this link: http://www.modbus.org/docs/Modbus_over_serial_line_V1_02.pdf

VERIFICATION OF INSTALLATION INSTRUCTIONS

Check the status of the blue ON/OFF LED after you switch on the power supply. (See **Fig. 10.**) The ON/OFF LED should blink during the initialization period (30 s) for 2 seconds at equal intervals of 2 second. Then it should give out continuous blue light. If this is not the case, check the connections again.

Fig. 10 Operating indication

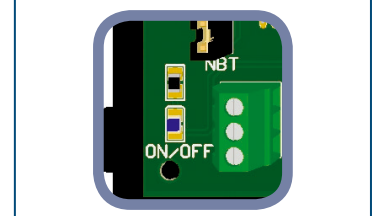

ATTENTION

If the internal communication with the sensor module is lost during installation or in case of an improper power supply, the outputs will rise (switch on) to maximum and the ON/OFF LED will start blinking quickly. Check input register 20 for the sensor status and if this is the case, contact authorised technical support or your sales representative.

TRANSPORT AND STOCK KEEPING INFORMATION

Avoid shocks and extreme conditions; stock in original packing.

WARRANTY INFORMATION AND RESTRICTIONS

Two years from the delivery date against defects in manufacturing. Any modifications or alterations to the product after the date of publication relieve the manufacturer of any responsibilities. The manufacturer bears no responsibility for any misprints or mistakes in this data.

MAINTENANCE

In normal conditions this product is maintenance-free. If soiled, clean with a dry or dampish cloth. In case of heavy pollution, clean with a non-aggressive product. In these circumstances the unit should be disconnected from the supply. Pay attention that no fluids enter the unit. Only reconnect it to the supply when it is completely dry.